

Quick Strat

SDM3045X Digital Multimeter

QS06034-E01A

Copyright Information

- SIGLENT TECHNOLOGIES CO., LTD. All rights reserved.
- The information provided in this manual replaces all information printed before.
- SIGLENT Company has the rights to change the specification and the price.
- Contents in this manual are not allowed to be copied, extracted and translated without permission by the company.

General Safety Summary

Read the following safety precautions carefully to avoid any personal injuries or damages to the instrument and any products connected to it. To avoid potential hazards, please use the instrument as specified.

Use proper power line.

It's only allowed to use the special power line which is approved by local state.

Ground the instrument.

The instrument is grounded through the protective terra conductor of the power line. The ground conductor must be connected to the earth to avoid electric shock. Make sure the instrument is grounded correctly before connecting its input or output terminals.

Connect the signal wire correctly

The potential of the signal wire is equal to the earth, so do not connect the signal wire to a high voltage.

Observe all terminal ratings

Please observe all ratings and sign instructions on the instrument to avoid fire or electric shock. Before connecting the instrument, please read the manual carefully to gain more information about the ratings.

Do not operate with suspected failures

If you suspect that the product is damaged, please contact SIGLENT's qualified service personnel to inspect it. Any repair and adjustment to the product or replacing a component should be done by qualified personnel only.

Avoid circuit or wire exposure

Don't touch exposed contacts or components when the power is on.

Don't operate without covers.

Don't operate the instrument with covers or panels removed.

Use proper fuse.

It's only allowed to use the specified fuse for the instrument.

Use proper overvoltage protection.

Make sure there is no overvoltage (like voltage caused by thunder and lightning) reaching to the instrument, otherwise the operator may suffer an electric shock.

Antistatic protection.

Static electricity will cause damages to the instrument, so test in antistatic areas as far as possible. Ground its inner and outer conductors to release the static electricity temporarily before connecting the cable to the instrument.

Keep good ventilation.

Improper ventilation will cause the rise of the instrument's temperature. Keep good ventilation and check the vent and fan regularly when using it.

Keep the surface of the instrument clean and dry.**Do not operate in wet or damp conditions.****Do not operate in flammable or explosive environment.**

The disturbance test of all the models meets the limit values of A in the standard of EN 61326-1:2013.

Input terminal protection limitation

Protection limitation is defined for the input terminal:

1. Main input (HI and LO) terminal

HI and **LO** terminals are used for Voltage, Resistance, Capacitance, Continuity, Frequency, Diode and temperature measurement. Two protection limitations are defined:

- **HI-LO protection limitation:** 1000VDC or 750AVC. It's the maximum measurable voltage. The limitation can be expressed as 1000Vpk.
- **LO-ground protection limitation:** **LO** terminal can "float" 500Vpk relative to the ground safely. The maximum protection limitation of **HI** terminal relative to the ground is 1000Vpk. Therefore, the sum of the "float" voltage and the measured voltage can't exceed 1000Vpk.

2. Sampling (HISense and LOSense) terminal

HISense and **LOSense** are used for 4-wire Resistance measurement. Two protection limitations are defined:

- **HISense-LOSense protection limitation:** 2000Vpk.
- **LOSense-LOSense protection limitation:** 2Vpk.

3. Current input (I) terminal

I and **LO** terminals are used for current measurement. The maximum current which go through the **I** terminal is limited to 10A by the fuse on the back panel.

NOTE:

Voltage on the current input terminal corresponds to voltage on **LO** terminal. To keep good protection, only use the fuse of specified type and level to replace this fuse.

IEC Measurement Category II Overvoltage Protection

SDM3045X Digital Multimeter provides overvoltage protection for line-voltage mains connections meeting both of the following conditions to avoid the danger of electric shock:

1. The HI and LO input terminals are connected to the mains under Measurement Category II conditions as following.
2. The maximum line voltage of the mains is 300VAC.

WARNING:

IEC Measurement Category II includes electrical devices connected to mains at an outlet on a branch circuit, such as most small appliances, test equipments, and other devices that plug into a branch outlet or socket.

SDM3045X is capable of making measurements with the **HI** and **LO** inputs connected to mains in such devices (up to 300VAC) or the branch outlet itself. However, the **HI** and **LO** terminals of SDM3045X can't be connected to mains in permanently installed electrical devices such as the main circuit-breaker panels, sub-panel disconnected boxes and permanently wired motors. Such devices and circuits are prone to exceed the protection limits of SDM3045X.

NOTE:

Voltages above 300VAC only can be measured in circuits that are isolated from mains. However, there may be transient overvoltage in circuits that are isolated from mains. SDM 3045X is able to withstand occasional transient overvoltage up to 4000Vpk. Please don't use this instrument to measure circuits that transient overvoltage may exceed this level

Safety Terms and Symbols

Terms in this manual. Terms may appear in this manual:

WARNING: Warning statements indicate the conditions and behaviors that could result in injury or loss of life.

CAUTION: Caution statements indicate the conditions and behaviors that could result in damage to this product or other properties.

CAT I (1000V): IEC Measurement Category I. The highest measurable voltage is 1000Vpk in the **HI-LO** terminal.

CAT II (300V): IEC Measurement Category II. Inputs may be connected to mains (up to 300VAC) under Category II overvoltage conditions.

Terms used on the instrument. Terms may appear on the instrument:

DANGER indicates an injury or hazard that may immediately happen.

WARNING indicates an injury or hazard that may not immediately happen.

CAUTION indicates that a potential damage to the instrument or other property might occur.

Symbols used on the instrument. Symbols may appear on the instrument:



**Hazardous
Voltage**



**Protective
Earth Ground**



Warning



**Test
Ground**



**Chassis
Ground**

Daily Maintenance and Cleaning

Maintenance

When storing or placing the instrument, please avoid the liquid crystal display from direct sunlight for a long time.

NOTE:

- To avoid damages to the instrument or test leads, please don't place them in mist, liquid or solvent.

Cleaning

Please often clean the instrument and test leads according to the use of them.

- Wipe the external ash of the instrument and test leads by a soft rag. Be careful not to scratch the transparent plastic protective screen when cleaning the liquid crystal screen.
- Use a soft rag that has been soaked by water to clean the instrument after cutting off the power. Or use 75% isopropyl alcohol of water solvent to get a more thorough cleaning.

NOTE:

- To prevent the surface of the instrument or test leads from damages, please don't use any corrosive or chemical cleaning reagents.

Please make sure the instrument is already dry before restarting it to avoid short circuits or personal injuries caused by water.

Content

Copyright Information.....	I
General Safety Summary	II
Safety Terms and Symbols.....	VI
Daily Maintenance and Cleaning.....	VII
General Inspection	1
Appearance and Size.....	2
To adjust the Handle	3
Front Panel.....	4
Rear Panel	5
Connect Power Cord.....	6
Power Selection.....	7
Change the Power Fuse.....	7
Connect Test Leads	8
Connect USB and LAN Ports.....	14
Use Safety Lock	15
Troubleshooting	16
Contact SIGLENT	18

General Inspection

1. Inspect the shipping container.

Please keep the damaged container or cushioning material until the contents of the shipment have been checked completely and the instrument has passed the electrical and mechanical test.

Damages of the instrument caused by the shipment will be compensated by the shipper or carrier. **SIGLENT** will not be responsible for the free repair or replacement.

2. Inspect the instrument.

If there exist any mechanical damages or lacking of components, or the instrument fails the electrical and mechanical test, please contact your SIGLENT sales.

3. Check the accessories.

Check the accessories according to the packing list carefully.

If there exist any accessories damaged or missing, please contact your **SIGLENT** sales.

Appearance and Size

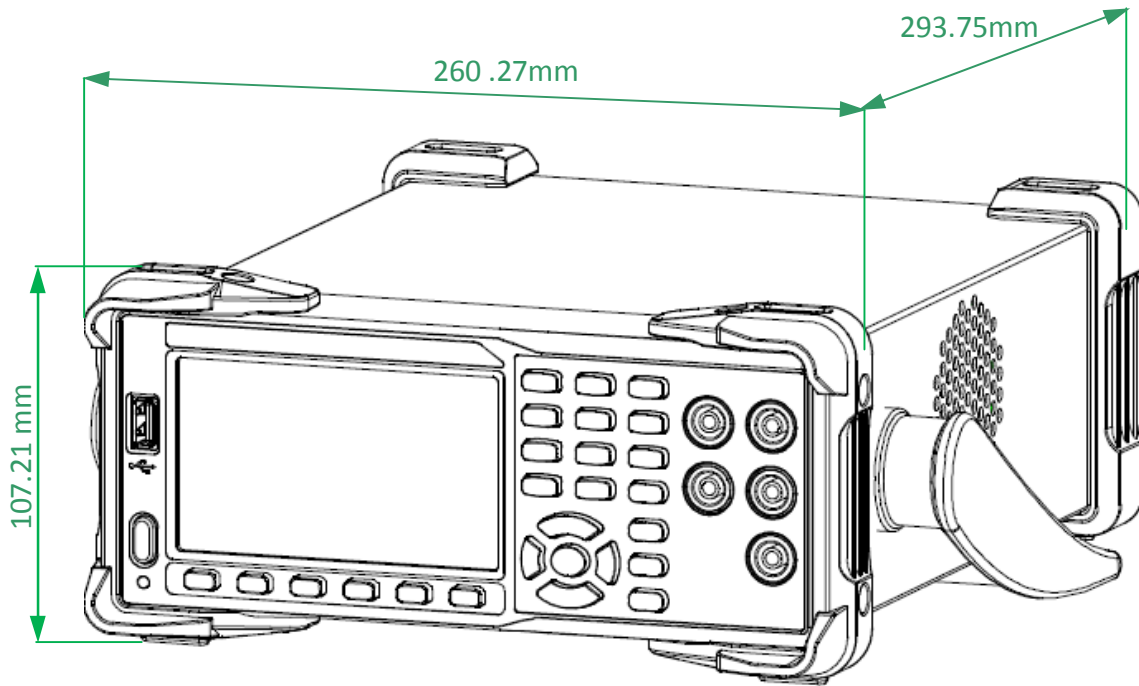

Appearance and Size

To adjust the Handle

Please grip the handle by the two sides and pull it outward to adjust the handle position of SDM3045X. Then rotate the handle to the appropriate position. Please operate as the following figure:

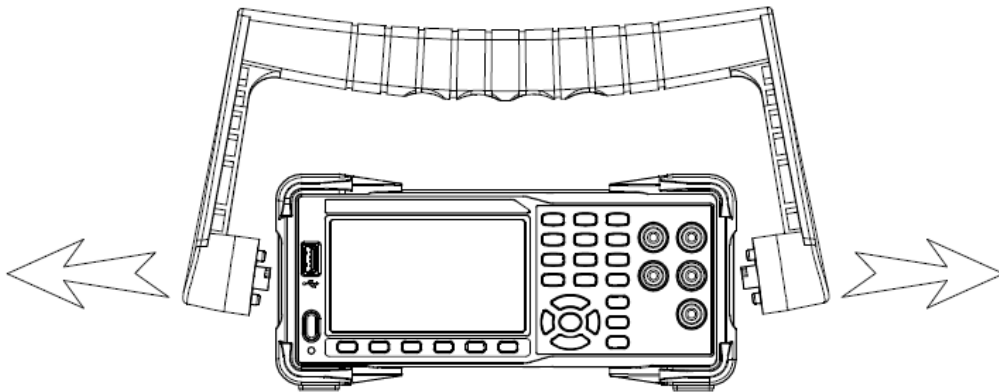

Handle Adjustment

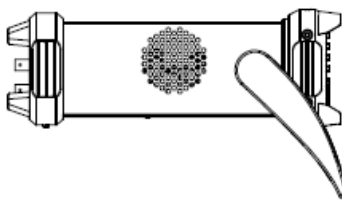
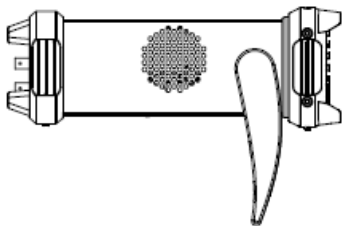
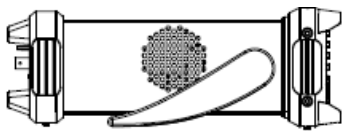

Horizontal Position

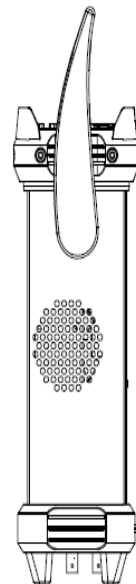

Carrying Position

Front Panel

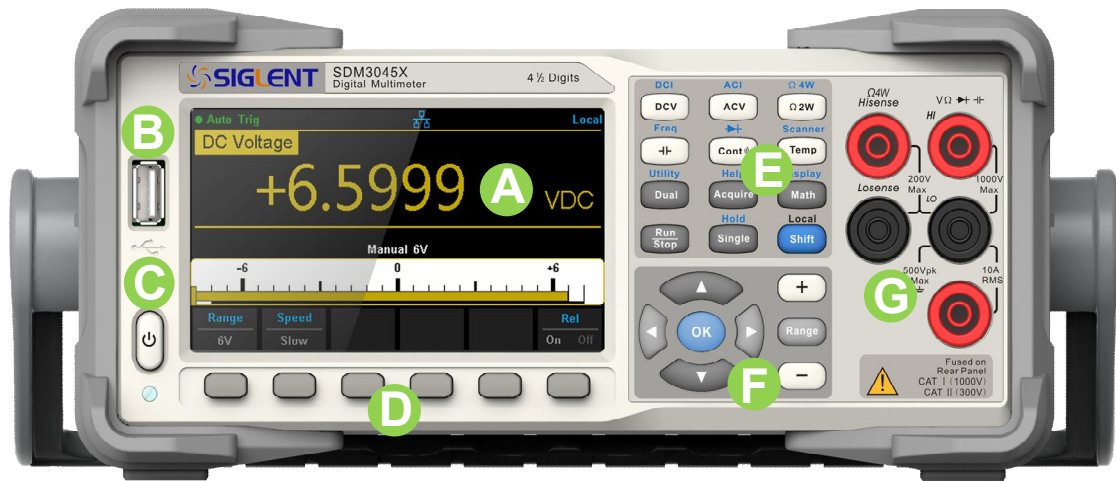

- A** LCD Display
- B** USB Host
- C** Power Key
- D** Menu Operation Keys
- E** Measurement and Assistant Function Keys
- F** Range and Direction Keys
- G** Signal input terminals

Rear Panel

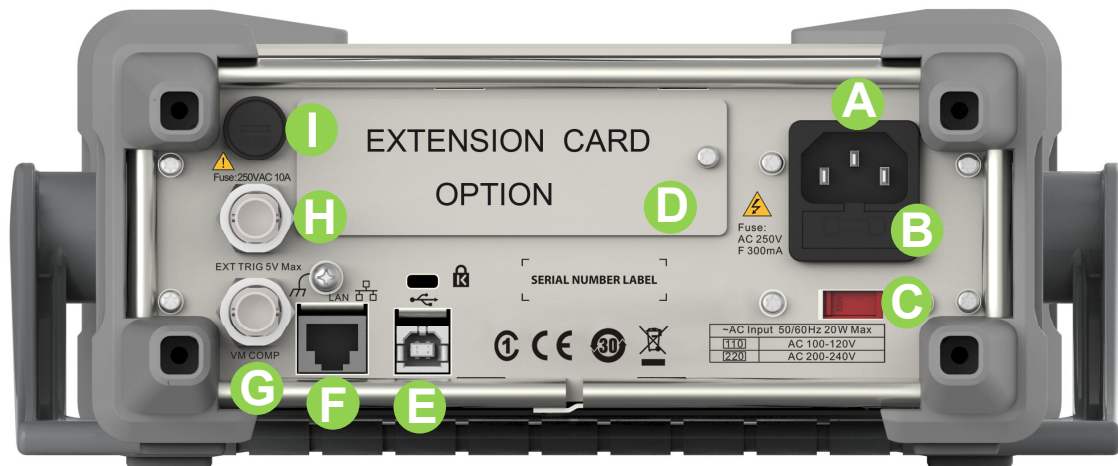

- A** Power Socket
- B** Power Fuse
- C** AC Voltage Selector
- D** Inspection card (option)
- E** USB Device
- F** LAN
- G** VMC Output
- H** Ext trigger
- I** Current Input Fuse

Connect Power Cord

Before connect the instrument to a power source, please select the AC voltage selector on the rear panel of your multimeter according to the power supply. Then connect the power cord as shown in the following figure.

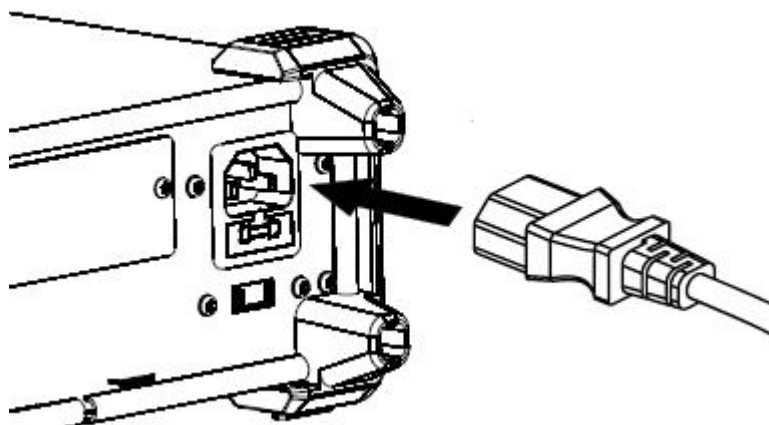

Connect Power Cord

Press the Power key on the front panel to start up the multimeter.

If unable to start up the multimeter, take the follow steps:

1. Check the power cord connection.
2. After the inspection, if the power key is not lit, please take out the fuse and check, refer to the fuse specification shown in the User Manual to change the fuse if needed.
4. After the above inspections, the power key is still not lit, please contact **SIGLENT** for help.

Power Selection

The Multimeter is able to operate on multiple power distribution standards and must be set up according to the supply voltage. If the selected supply voltage doesn't match the working voltage while using, the setting of the Multimeter's supply voltage must be changed. The power selector is located under the power fuse on the rear panel.

Change the Power Fuse

The power fuse is located in the fuse block on the back panel. The Multimeter has installed a power fuse before leaving the factory. It's a kind of fast-melt, no-burst, F300mA, 5×20mm one.

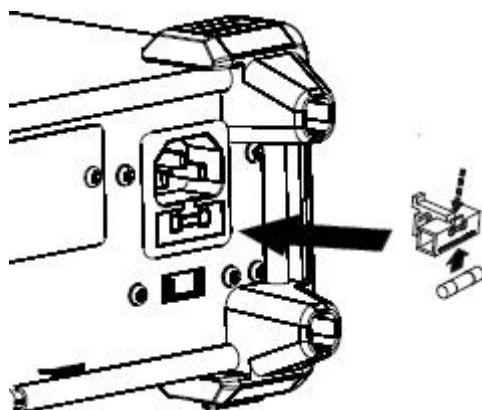

Change the fuse

Connect Test Leads

1. DC Voltage Measurement

Connect the test leads and tested circuit as the following figure, red test lead to the HI Terminal and black lead to the LO Terminal.

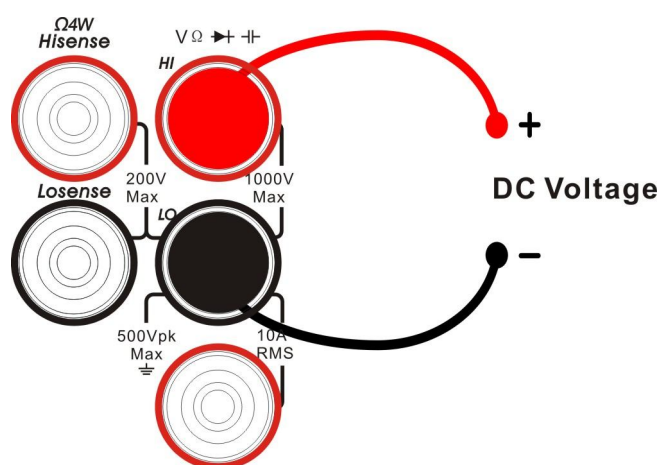

2. AC Voltage Measurement

Connect the test leads and tested circuit as the following diagram, red test lead to the HI Terminal and black lead to the LO Terminal.

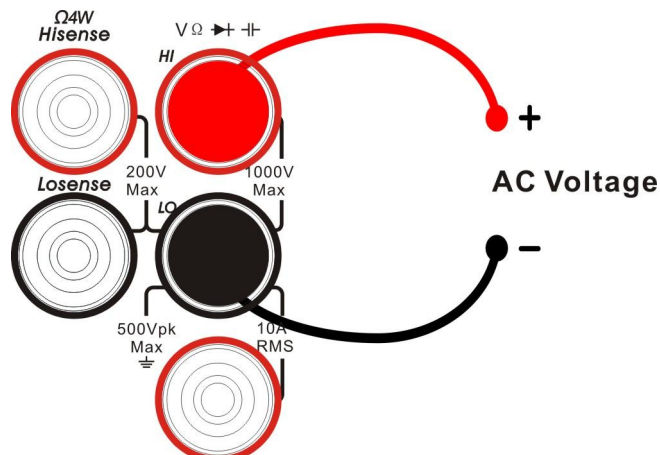

3. DC Current Measurement

Connect the test leads and tested circuit as the following diagram, red test lead to the HI Terminal and black lead to the LO Terminal.

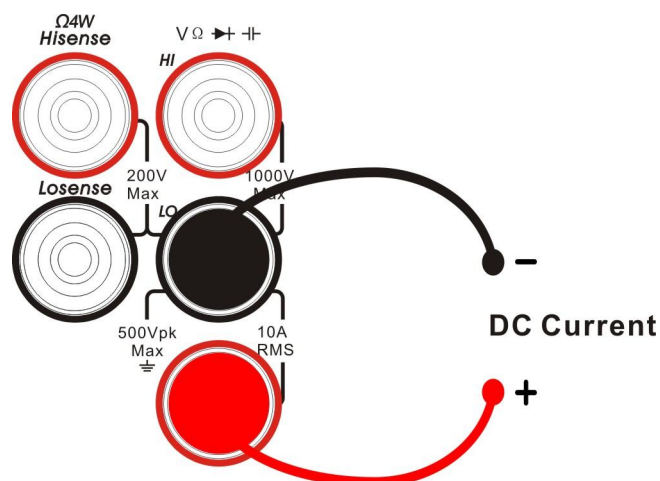

4. AC Current Measurement

Connect the test leads and tested circuit as the following diagram, red test lead to the HI Terminal and black lead to the LO Terminal.

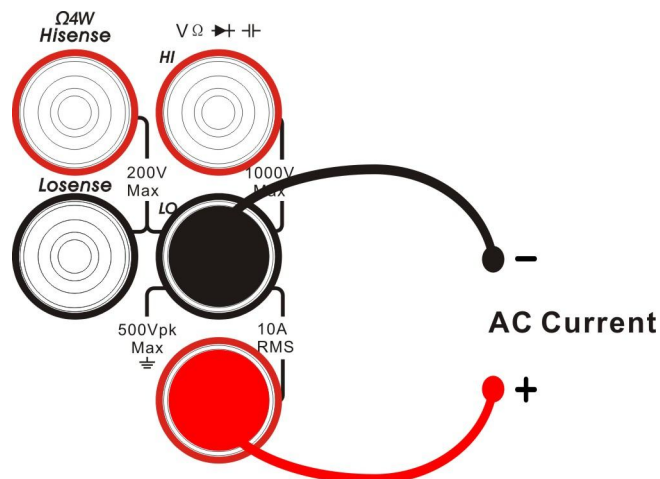

7. Capacitance Measurement

Connect the test leads and tested capacitor as the following diagram, red test lead to the positive pole of the capacitor and black lead to the negative pole.

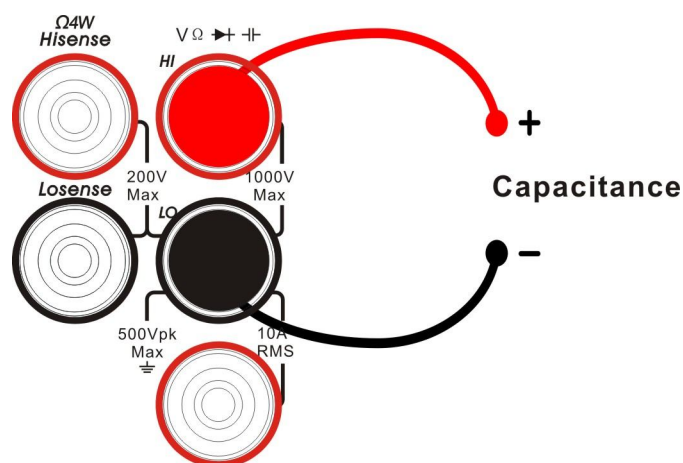

8. Continuity Testing

Connect the test leads and tested circuit as the following diagram, red test lead to the HI Terminal and black lead to the LO Terminal.

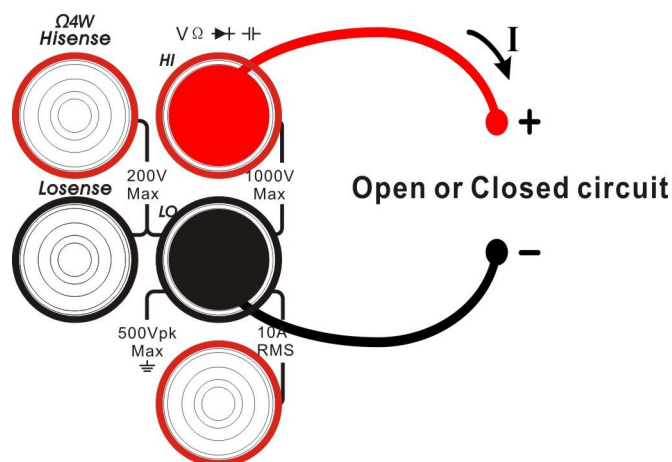

9. Diode Testing

Connect the test leads and tested diode as the following diagram, red test lead to the HI Terminal and black lead to the LO Terminal.

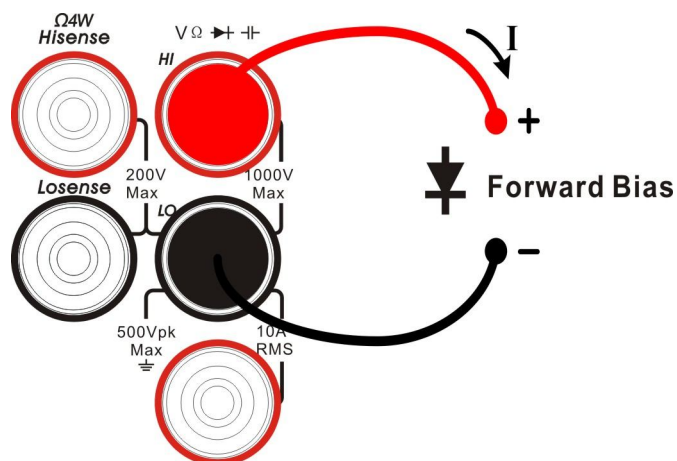

10. Frequency/Period Measurement

Connect the test leads as the following diagram, red test lead to the HI Terminal and black lead to the LO Terminal.

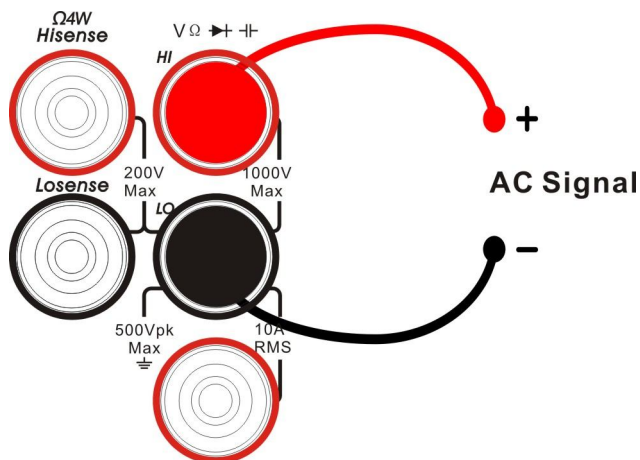

11. Temperature Measurement

Connect the test leads and tested circuit as the following diagram, red test lead to the HI Terminal and black lead to the LO Terminal.

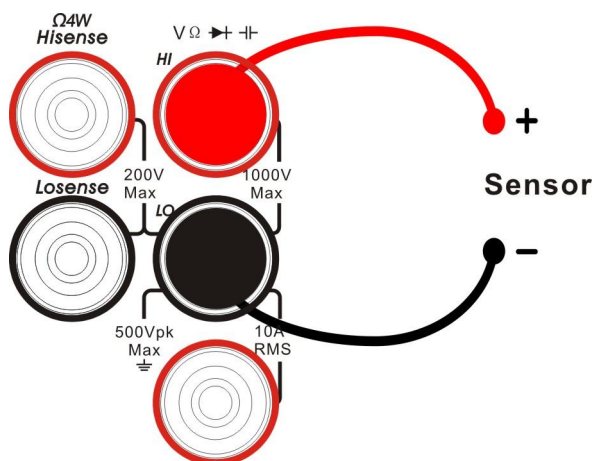

TC and RTD Sensor

Connect USB and LAN Ports

SDM3045X has plenty of I/O ports. To use any of the ports, follow the next instruction:

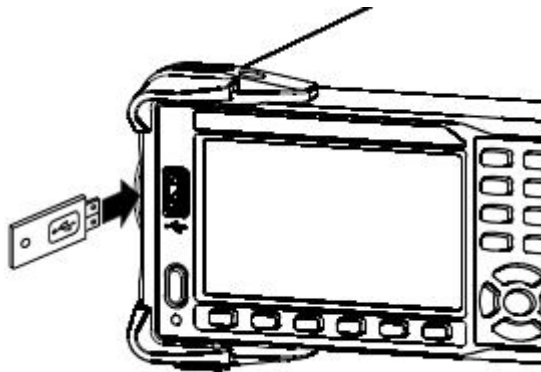

Connect USB Host

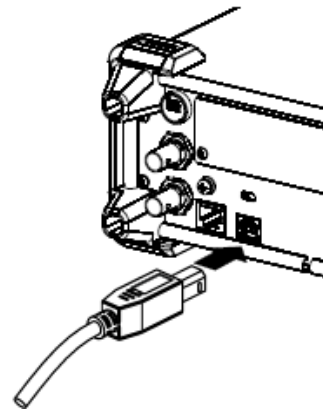

Connect USB Device

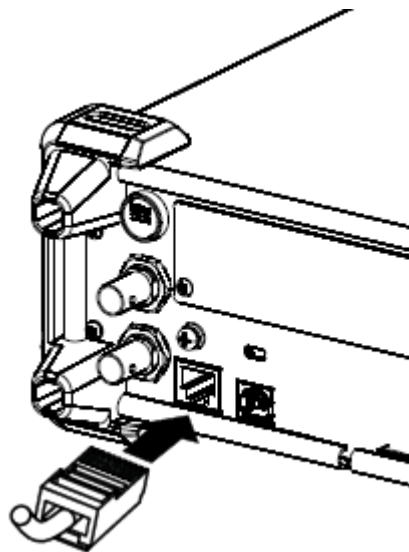

Connect LAN

Use Safety Lock

You can use the safety lock to lock the multimeter in a fixed place if necessary. The methods are as the following:

1. Align the key into the keyhole in the vertical direction of the back panel.
2. Then rotate clockwise to lock the multimeter.
3. Remove the key at last.

Troubleshooting

The general failures and consequential solutions are listed below. When you find them, please deal with them in the following corresponding ways. If the problem proves to be unsolvable by yourself, please contact **SIGLENT** for help.

1. If the screen is still dark with nothing displayed after pressing the power key:

- (1) Check if the power is correctly connected.
- (2) Check if the power fuse has blown. Replace it if necessary.
- (3) If the instrument still can't start up properly, please contact SIGLENT.

2. The reading doesn't change when connecting an AC current signal:

- (1) Check if the test lead is correctly connected to the current jack or LO jack .
- (2) Check if the fuse in the current location on the back panel has blown.
- (3) Check if the measure location has switched to the DCI or ACI place correctly.
- (4) Check if the input is ACI but the measure location is in

DCI place。

3. The reading doesn't change when connecting a DC current signal:

- (1) Check if the test lead is correctly connected to the current jack or LO jack.
- (2) Check if the fuse in the current location on the back panel has blown.
- (3) Check if the measure location has switched to the DCI or ACI place correctly.
- (4) Check if the input is DCI but the measure location is in ACI place.

4. USB storage can't be recognized:

- (1) Check if the USB can work normally.
- (2) Make sure that the USB storage being used is of flash type, the instrument does not support USB of hardware type.
- (3) Make sure that the capacity of the USB storage is not too large. It is suggested that the capacity of the USB matches to the multimeter is no larger than 4 G.
- (4) Restart the instrument and then insert the USB to check it.
- (5) If it is still in abnormal use, please contact **SIGLENT**.

Contact SIGLENT

SIGLENT TECHNOLOGIES CO.,LTD

Address: 3/F, building NO.4, Antongda Industrial Zone, 3rd
Liuxian Road, Bao'an District, Shenzhen, P.R.China

Tel: 0086-755-3661 5186

E-mail: sales@siglent.com

[Http://www.siglent.com](http://www.siglent.com)